



T E C H 2 0 1 3

ERRORS ONLY

This is a quick reference guide. Please refer to the primary group for further information.

Motherboard

- **CMOS Checksum error:** The CMOS battery is failing and needs to be replaced.
- **CMOS error defaults loaded:** The CMOS battery is failing and needs to be replaced.
- **The firmware has detected that a CMOS battery failure occurred. Press the Enter key continues.** Intel MB.
- **Kernel panic - not syncing: Fatal exception:** This error is related to a physical memory.
Possible compatibility issue with motherboard when installing updated memory from 128MB to 512 MB.

I/O board

- **Fatal error cannot access I/O board:** This indicates that the motherboard does not detect I/O board.
- **Printer error:** Defective I/O board. I/O board needs to be replaced. Printers are use for German games.

Security Key

- **Invalid key for version PG3002-01 V2X.00** – software does not match key version.
- **Key Range Mismatch:** The security key and software do not match completely.
- **No security detected:** No security key is being detected.
- **Force key detected in Ion system for version PG3002-01 VXX.XX:** Force key installed into an Ion game.
- **Ion key detected in Force system for version PG3002-01 VXX.XX:** Ion key installed into a Force game.

Hard drive

- **LiLo-Keytable read/check sum error:** (Linux boot loader) indicates a corrupted hard drive.
- **Disc Boot Failure:** Indicates a defective hard drive. Related to ECS motherboards.
- **Reboot and select proper boot device or insert boot media in selected boot device and press a key:**
Indicates a defective hard drive. Related to ASUS motherboards. (Same as disc boot failure.)
- **A bootable device has not been detected:** Related to the Intel motherboards.
- **CRC error:** Indicates defective hard drive.
- **Operating System Not Found:** May indicate a defective hard drive. (Maxx platform)
- **Interrupt 18H Check cable...:** Indicates a defective hard drive. (Force platform)
- **Error 64, 67, 94, & 97:** Indicates a defective hard drive (seen during download of new software).
- **Verifying DMI Pool:** This error message can be related to a failed motherboard or a failed hard drive.
- **Error 18 failed opcode:** Hard drive failure: Kernel issue.
- **Error #97:** Defective 2.5" HDD adapter for laptop IDE hard drives.
- **Grub Loading stage 1.5 Read error:** Possible SATA data cable or SATA\IDE adapter or 2.5" HDD adapter.
- **Grub Error 15:** Problem with the master boot loader; Corrupted hard drive.
- **Error 16: Inconsistent filesystem structure:** File system corruption. Possible reload hard drive.
- **Kernel Panic Unable to mount root 305:** SATA hard drive loaded with 2006 through 2008.5 software being installed Into SATA based ASUS or Intel motherboards. Requires IDE to SATA adapter.

Corrupted Hard Drive

- **Bad Command or File Name:** This may indicate a corrupted hard drive or motherboard (corrupt CMOS).
- **Kernel Panic:** Possible defective motherboard, hard drive, IDE ribbon cable or SATA\IDE adapter.
- **Checking for bad blocks:** Corrupted hard drive.
- **Mounting other file system – failed:** Corrupted hard drive.
- **Rebooting to perform maintenance:** Corrupted hard drive.
- **Starting system logger:** Linux: Corrupted hard drive.

Downloading

- **Error Detected #96:** Defective DVD (disc). Problem occurs during download of software.
- **Error 13.9:** Possible defective set of CD\DVDs or a defective CD\DVD-ROM drive.
- **Error detected #8:** Defective IDE cable or defective hard drive.
- **Error 1:** Possible Hard drive problem or DVD ROM drive.
- **hdc: lost interrupt:** Kernel failed. Possible DVD ROM drive, hard drive or DVD disc or interface cable.
- **Disk error 10 AX=42BB:** Defective DVD ROM drive.

Touchscreen

- **Touch Screen Controller Error:** This indicates that the motherboard does not detect the controller.
- **Touch Screen Controller not Responding:** This indicates that the motherboard does not detect the controller.

No video being displayed

Following messages indicate that the monitor LCD\CRT is functioning. Possible motherboard or power supply issue.

- **Cable disconnected D-Sub Analog**
- **Powersave Mode D-Sub**
- **No Input signal, check connector**
- **No Video**
- **Auto Test**
- **No sync**

ION HARDWARE

Motherboards:

ECS

CPU: AMD 1.8 GHz

Memory: 128MB \ 256MB \ 512MB PC2700 DDR 333MHz (DDR – Double Data Rate)

Memory: 512MB for Ion 2012 & 2013 software.

TechTip: No video or sound? Try reseating DDR DIMM.

ASUS

CPU: AMD 1.8 GHz

INTEL

CPU: Intel Atom 1.6 GHz

Memory: 512 MB \ DDR2 533/667 MHz DIMMs.

TechTip: ECS and ASUS motherboards do not emit an audio tone when DDR DIMM is defective or not seated correctly.

Kernel Panic: Possible defective motherboard, hard drive, or IDE ribbon cable.

I/O board (Titan I/O board)

- 4 LEDs: D1, D2, D3, & D8.
- Setup and Calibration buttons are located on the I/O board and OSD board.

OSD Board (On Screen Display)

Features:

- Setup & Calibrate buttons.
- Program security key.
- LCD video control buttons.

TechTip: The RX only uses LCD controls on the OSD board.

ION SOFTWARE

ION 2006

Version: V20.00 – V20.27

Security Key: SA3505-XX

ION 2006.5

Version: V21.51

Security Key: SA3505-XX

ION 2007

Version: V22.00 – V22.10

Security Key: SA3522-XX // SA3523-XX

ION 2007.5

Version: V23.00

Security Key: SA3522-XX // SA3523-XX

ION 2008

Version: V24.05

Security Key: SA3547-XX // SA3548-XX

ION 2008.5

Version: V25.00

Security Key: SA3547-XX // SA3548-XX

ION 2009

Version: V29.XX // V30.XX (Ver: 2009.XX)

Security Key: SA3559-XX // SA3560-XX

ION 2009.5

Version: 31.02

Security Key: SA3559-XX // SA3560-XX

ION 2010

Version: V32.02 – V32.11

Security Key: SA3590-XX

ION 2010.5

Version: V33.XX

Security key: SA3590-XX

ION 2011

Version: V34.01

Security Key: SA3605-XX // SA3607-XX

ION 2011.5

Version: V35.00

Security Key: SA3605-XX // SA3607-XX

ION 2012

Version: V36.XX

Security Key: SA3614-XX // SA3617-XX

ION 2013

Version V38.XX

Security Key: SA3623-XX // SA3624-XX

FORCE HARDWARE

Motherboard:

ECS

CPU: Intel Celeron 533/566 MHz

Memory: DIMM – Dual Inline Memory Module (PC133)

- **Invalid motherboard configuration:** Proper CMOS configuration needs to be performed. See Force ECS configuration.

I/O Boards:

3 in 1 I/O board (T-Shaped I/O board)

- Used in eVo, Edge, Walette, & Fusion systems, and it is not interchangeable with the USB I/O board.

USB I/O Board (square I/O board)

- Used in the Radion, Elite, Vibe, Classic, 19" Upright, and Mr. VIPs.
- USB I/O jumper settings for the Force Series games:

J5B - USB port setting for Elite & Upright games.

J5A - USB port setting for Radion & Classic games.

J5B



JP6 JP5

J5A



JP6 JP5

TechTip: If the jumpers are not set correctly, the I/O board will display an "Invalid Key" error.

TechTip: Check I/O board LEDs for voltages: Diodes D1: +3vdc; D2: +5vdc; D4: VSS; D3: USB VCC.

All four LEDs should be lit red. If not, an "Invalid Key" error will appear.

Setup and Calibration buttons are located on the I/O board and OSD board.

FORCE SOFTWARE

FORCE 2002

Version: V8.00 - V8.06

Security Key: SA3050-XX

FORCE 2002.5

Version: V9.00 - V9.01

Security Key: SA3050-XX

FORCE 2003

Version: V10.00 - V10.09

Security Key: SA3059-XX

FORCE 2003.5

Version: V11.00 - V11.05

Security Key: SA3059-XX

FORCE 2004

Version: V12.00 - V12.10

Security Key: SA3068-XX

FORCE 2004.5

Version: V13.00 - V13.10

Security Key: SA3068-XX

FORCE 2005

Version: V14.00 - V14.22

Security Key: SA3083-XX

FORCE 2005.5

Version: V15.11

Security Key: SA3083-XX

FORCE 2006

Version: V20.00 – V20.27

Security Key: SA3501-XX // SA3504-XX

FORCE 2006.5

Version: V21.05

Security Key: SA3501-XX // SA3504-XX

FORCE 2007

Version: V22.00 - V22.10

Security Key: SA3526-XX

FORCE 2007.5

V23.00 - V23.02

Security Key: SA3526-XX

FORCE 2008

Version: V24.04

Security Key: SA3542-XX // SA3543-XX

FORCE 2008.5

Version: V25.00

Security Key: SA3542-XX // SA3543-XX

FORCE 2009

Version: V26.XX

Security Key: SA3570-XX // SA3572-XX

FORCE 2009.5

Version: V27.00

Security Key: SA3570-XX // SA3572-XX

FORCE 2010

Version: V28.00

Security Key: SA3579-XX

FORCE 2010.5

Version: V28.10 - V28.20

Security Key: SA3579-XX

FORCE 2011

Version: V28.30

Security Key: SA3603-XX // SA3604-XX

CMOS CONFIGURATIONS

CMOS stores information such as the date, time, and system configuration settings on the motherboard.
CMOS battery: CR2032 (3.0 VDC lithium battery)

INTEL (ION)

- 1 - Plug the keyboard into PS2 (purple) port or the USB port on the motherboard.
- 2 - Press **Del** or **F2** on the keyboard to enter **System Setup**.
- 3 - Press **F9** to **Load Defaults**, then select "**Y**" for yes.
- 4 - Arrow down to **System Date** and **System Time**.
- 5 - Adjust the System Date & Time (instructions for adjustments are on the screen to lower right corner).
- 6 - Press **F10** (Exit Saving Changes). Select "**Y**" for yes. The system should reboot. Unplug the keyboard.

ASUS (ION)

- 1 - Plug the keyboard into PS2 (purple) port or the USB port on the motherboard.
- 2 - Power the game on. Press and hold the **Del** key to enter the **BIOS SETUP UTILITY** screen.
- 3 - Once you're at the **BIOS SETUP UTILITY** screen, arrow over to **EXIT**.
- 4 - Arrow down to **LOAD SETUP DEFAULTS**.
- 5 - Press **Enter**. Select **OK**.
- 6 - Arrow back to **MAIN**, and adjust the **System Time** and **System Date**.
- 7 - Arrow back over the **EXIT** screen.
- 8 - With the **EXIT & SAVE CHANGES** already highlighted, press **Enter**. Select **OK**.
- 9 - The system should reboot. Unplug the keyboard.

ECS (ION)

- 1 - Plug the keyboard into PS2 (purple) port or the USB port on the motherboard.
- 2 - Power the game on. Press **Del** to enter **SETUP**.
- 3 - Arrow over and down to **Load Optimized Defaults**.
- 4 - Press **Enter**. Press **Y** for **Yes**, and then press **Enter**.
- 5 - Arrow back up and over to **Standard CMOS features**, then press **Enter**.
- 6 - Adjust the date and time, then press **Esc**.
- 7 - Press **F10**, press **Y** for **Yes**, then press **Enter**.
- 8 - The system should reboot. Unplug the keyboard.

ECS (FORCE)

- 1 - Plug the keyboard into PS2 (purple) port or the USB port on the motherboard.
- 2 - Power the game on. Press **Del** to enter **SETUP**.
- 3 - Arrow over and down to **Load Fail-Safe Defaults**.
- 4 - Press **Enter**, and then select **Y** for **Yes**.
- 5 - Arrow over and down to **Load Optimized Defaults**.
- 6 - Press **Enter**. Then press **Y** for **Yes**.
- 7 - Arrow back over to Standard CMOS features, then press **Enter**.
- 8 - Adjust the date and time, then press **Esc**.
- 9 - Press **Enter**. Press **F10** and then press **Enter**.
- 10 - The system will reboot. Unplug the keyboard.

Instructions to change the date and time are normally explained on the actual display screen.

Keyboards: Both the USB port or PS2 port (purple port) will work with Force and Ion version motherboards.

TechTip: DIP switch 8 (DS8) should be tried first before doing a keyboard CMOS.

TechTip: Do not connect a PS2 keyboard to the motherboard when it's powered up.

There is a strong chance of damaging the PS2 port on the motherboard.

CMOS ERRORS

ECS & ASUS Motherboards (ECS Force & Ion)

- Failing CMOS battery: The ECS motherboards will display an error message similar to “**CMOS Checksum error**”. This would mean the battery is failing and needs to be replaced.
- Failed CMOS battery: If the CMOS battery has completely failed, the motherboard will not power up.

Procedure: Once the battery is replaced, jumper the green and black wires (using a paperclip for example) coming from the power supply. With the jumper is in place, connect the keyboard (PS2 or USB) to the motherboard and turn the game on. Simply follow the proper motherboard configuration from the CMOS configuration section in this TECH 2013 document.

Intel Motherboards

If the CMOS battery fails on an Intel motherboard, the game will power up and the screen will display the following message:

The firmware has detected that a CMOS battery failure occurred. Press the Enter key to continue.

To resolve this, replace the CMOS battery (if need be) and just follow the CMOS configuration for the Intel motherboard.

Possible causes

- External: Electrical disturbance or thunderstorms.
- Internal: Reverse polarity or AC outlet problems.
- Defective CR2032 lithium 3.0-volt battery.
- Defective motherboard.

Ports

- No touch controller found. (Verify that the green LED on the controller is active by touching the screen.)
- Fatal error, cannot access I/O board (2006 through 2013 software).
- Invalid key error: Motherboard not USB port.
- Disc boot failure or operating system not found. Primary IDE port (Hard Drive).
- Loading problem: Secondary IDE port: CD\DVD drive cannot be accessed.
- No modem detected: MegaNet (international) or Tournamaxx (US & Canada).
- No sound or audio.

I/O BOARD

Problem: Error message:

Fatal error cannot access I/O board: This indicates that the motherboard does not detect I/O board.

Possible causes:

- Software: Corrupt hard drive – reload software.
- Motherboard: Defective motherboard.
- I/O board: Defective I/O board – 4 red LEDs need to be active or lit for correct I/O board function.
- Harness problem: Broken wire at pin connector harness.
- Power connection: Check power supply connector.

TechTip: Related to 2006 through 2013 versions of software.

TechTip: The DIP switches will not function if the I/O board is not communicating with the motherboard.

LEDs Voltages	USB	+3 VDC	+ 5 VDC	+12 VDC
Ion Titan I/O	D1	D8	D2	D3
Force 3in1 I/O	D3	D1	D2	D4
Force USB	D3	D1	D2	D4

LED scenarios:

1 LED active: USB cable is connected and the power supply connector is not connected.

2 LEDs active: Possibly a faulty I/O board.

3 LEDs active: Power supply connector is connected and USB cable is not connected.

4 LEDs active: I/O BOARD has all applied voltages and USB connection.

TechTip: Although all the 4 LEDs are active, the I/O board can still be faulty.

2006

- Possible touch controller related problem.

Printer error:

- Defective I/O board. This will indicate that the I/O board needs to be replaced. Printers are used for games manufactured for Germany.

NO POWER UP

The term **POST** is **Power-On Self-Test** and is an initial set of diagnostic tests performed on power-up by the computer.

ECS Motherboards: Ion

No power-up: No DC voltage. Failed CMOS battery:

If the CMOS battery has completely failed, the motherboard will not power up.

Procedure: Turn the game off and replace the CMOS battery. Connect the keyboard (PS2 or USB) to the motherboard. Next, short or jumper the green and black wires from the power supply (using a paperclip for example), then power the game up. If there is DC voltages (the fan function for example), check to see if there is print on the screen displaying "CMOS Checksum error". If there is, follow the ECS motherboard CMOS configuration section in this TECH 2013 document.

Power-up \ POST: The ECS motherboards will display an error message similar to "CMOS Checksum error".

This would indicate that the battery is failing and needs to be replaced.

Procedure: Turn the game off and replace the CMOS battery. Connect the keyboard (PS2 or USB) to the motherboard. Next, short or jumper the green and black wires from the power supply (using a paperclip for example), then power the game up. If there is DC voltages (fan function for example), check to see if there is print on the screen displaying "CMOS Checksum error". If there is, follow the ECS motherboard CMOS configuration section in this TECH 2013 document.

Power-up \ No POST: With the CMOS battery replaced, short or jumper the green and black wires from the power supply (using a paperclip for example) and then power the game up. If there is DC voltages (fan function for example) and no print displayed on the screen after 5 -10 seconds, this indicates another problem. Proceed to the [Hardware Components](#) section.

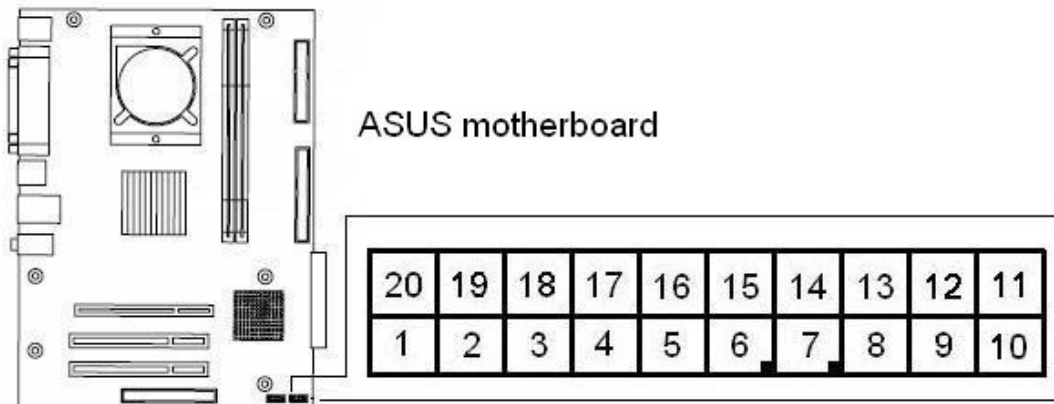

ASUS Motherboards: Ion

No-power-up: No DC voltage. Failed CMOS battery:

If the CMOS battery has completely failed, the motherboard will not power up.

Procedure: Turn the game off and replace the CMOS battery on the ASUS motherboard.

Connect the keyboard (PS2 or USB) to the motherboard. Remove the POWER-ON connector.

Locate the PWR SW pins. Locate pins 6 & 7. Turn the game back on.

Carefully touch the pins 6 & 7 very quickly; the fans and LEDs (for example) should start functioning.

Check the video screen. Is there should be print on the screen?

Yes: Precede with the ASUS motherboard CMOS configuration from in this TECH 2013 document.

No: Proceed to [Hardware Components](#) section.

Power-up/No POST: DC voltage is being produced with no picture.

Remove and check the CMOS battery. If the battery is under 3.0 volts DC it will need to be replaced.

Once the battery is replaced, locate the POWER-ON jumper, then locate the PWR SW pins. This will be pins 6 & 7.

Remove the power-on jumper, then turn the game back on. Carefully touch the pins 6 & 7 very quickly; the fans and LEDs (for example) should start functioning. Look at the video screen, there should be print on the screen.

Hardware Components

- DIMM: Try reseating the DIMM (memory stick). Motherboards missing or having defective memory will not POST.
- Power supply: A weak power supply will not have enough wattage to power up the motherboard.
- Motherboard: A defective motherboard will not power up.

ECS motherboard: Force

Problem: Game powers up and shuts down after 3-5 seconds. (Time variation may defer.)

At this point, depending on the age of the motherboard and power supply, both components could be at fault.

Both motherboard and power supply need to be in good condition to past POST.

- Power supply: Weak power supply.
- Motherboard: Defective motherboard.

VIDEO ERROR MESSAGES

No video being displayed

- Cable disconnected D-Sub Analog
- Powersave Mode D-Sub
- No Input signal, check connector.
- No Signal.
- Auto Test.
- NO sync (RX only)

These error messages are being generated by the video monitor and not by the motherboard.

It is the default state of the monitor. This indicates that the motherboard is not turning on.

The following may help resolve this problem:

- **Video Cables:** Try reseating the VGA cable to the motherboard.
- **DIMM:** Reseating the DIMM on the motherboard. (This applies to Ion ECS and ASUS motherboards.)
- **Power supply:** Weak power supply.
- **Motherboard:** Defective motherboard. Replace motherboard.

TechTip1: Ion ECS and ASUS motherboards do not emit an audio tone if the DIMM is not seated or has dirty edge pins.

NO SOUND

The game operates correctly, but no sound is being produced – provided that the volume level up is at the midway point in the “Volume Control” setting under “System”, this can be accessed through the operator SETUP button.

Troubleshooting procedure:

DIP switches:

Using the DIP switches (DS) try a DS6 (device drivers) first and then DS8 (CMOS configuration); or by directly going to the DS4 & 7 (factory default).

TechTip: Memory corruption can cause no audio problem.

Tools: MP3 player and headphones with 1/4” (3.5mm) stereo plug.

Motherboard:

With the game turned off, unplug the 1/4” (3.5mm) stereo plug from the green port on the motherboard.

Connect the headphone set into the green port on the motherboard, and turn the game back on.

Allow the game to boot up completely. When touching the touchscreen, is any sound being produced through the headphones?

- Positive for sound: This would indicate that the motherboard is functioning correctly. Possible I/O board problem.
- Negative for sound: This would indicate a motherboard problem or corrupted hard drive (software).

I/O Board:

With the game turned off and the 1/4” (3.5mm) stereo plug disconnected from the green port on the motherboard, connect the 1/4” (3.5mm) stereo plug into the MP3 player. With MP3 turned on and the game turned back on: Is the MP3 producing sound through the game speakers?

- Positive for sound: I/O board is functioning correctly and speakers and wire harnessing are good.
- Negative for sound: This would indicate a defective I/O board.

TechTip: Verify that the speakers and wiring are connected and not damaged.

GAME OUT OF SERVICE

Game Out of Service: Certain MegaNet games have an Internet-connection-required security key.

Broadband connection: Game has a connection-required key that has not connected to Internet server for 30 days or more. This is a broadband connection problem. Example: Defective router, no broadband service, wireless adapter issue...

Security Key Issue: Game had a connection-required key that was replaced with a standard key.

This requires a memory clear using the DIP switch 4 & 7 procedure done with the security key removed.

Once the screen indicates "No security key detected" simply re-install the security key during the five reboot attempts.

An update from server should be done first, provided the game is still involved in the MegaNet system

Memory corruption: The game never had a connection-required key. This is a result of memory corruption.

This requires a memory clear using the DIP switch 4 & 7 procedure done with the security key removed.

Once the screen indicates "No security key detected" simply re-install the security key during the five reboot attempts.

COIN JAM ERROR

Problem: "Coin Jam" error message.

Coin jam occurs at boot up after loading.

- Defective coin acceptor.
- Defective note acceptor
- Defective I/O board.
- Defective OSD board.
- Wiring harness problem. Check wiring harnesses.
- Wrong jumper settings—New I/O board installed. Check jumper settings. Compare new I/O with the old I/O board.

Coin jam occurs randomly: During attract mode or game play.

- Jumpers or shunts have poor or dirty contact connections.
- Connector has dirty or poor contact connection.
- Dirty sensors on the opto board (Imonex coin mech U.S. games only).
Try cleaning the optic sensors with compressed can of air or a clean paint brush.

Troubleshooting coin jam:

Start with pressing the **SETUP** button, touch the **DIAGNOSTICS** icon on the screen, then touch **I/O Test**.

On the **I/O Test** screen are any of the channels highlighted green? If so, what channels are highlighted green?

All channels are green: Possible jumper/shunt issue or wiring harness problem.

Try pulling the jumper/shunt off and on a few times; this creates a cleaning of the metal surfaces.

Single channel running:

- Defective coin acceptor.
- Defective note acceptor.
- Defective I/O board.
- Wrong jumper settings

Multiple channels running:

- Defective I/O board.
- Wiring harness problem. Check wiring harness.
- Wrong jumper settings: I/O board installed. Check jumper settings. Compare new I/O board with the old I/O board.

US games:

Channel 1 = U.S. quarters (coins)

Channel 2 = Note acceptor (U.S. dollar bills)

Channel 6 = U.S. dollar coins (Aurora, Aurora WS, and RX only)

International games:

- Coin acceptor: Mars Cashflow 330
- Notes acceptor: Smiley note acceptor

INVALID KEY

The security key is a copyright protection device. Security keys can be programmed for different versions of software depending on laws or requirements for a particular state or country.

SA3523-01 is an Ion 2007 security key. The **SA3523** is the base number. The **-01** represents US standard.

Invalid key error

All Games

- Invalid key for version: Software does not match key version.
- Corrupted CMOS configuration: Reconfigure motherboard CMOS configuration and check time & date.
Check CMOS configuration section in this TECH 2013 document.

Software:

- Corrupted hard drive: Try a DIP switch 4 & 7 memory clear procedure.
- Corrupted hard drive: Reload software using CDs/DVDs.

Hardware:

- **USB cable:** Defective USB cable. Make sure the USB cable is seated all the way at the I/O board and motherboard.
- **I/O Board:** Defective I/O board.
- **OSD Board:** Defective OSD board will cause invalid key. Move security key to I/O board and disconnect OSD board.
- **2 SECURITY KEYS:** Invalid key error will occur if there is a security key on the OSD board and a security key I/O board.
- **No security detected:** A defective I/O board can be responsible for generating this error message.
- Defective security key.

Error messages: 2007, 2008, 2009, 2010, 2011, 2012 & 2013

- Force key detected in Ion system for version PG3002-01 VXX.XX.
- Ion key detected in Force system for version PG3002-01 VXX.XX.
- No security key detected for version PG3002-01 V2X.XX – no security key present.
- Invalid key for version PG3002-01 V2X.00 – software does not match key version.
- Key Range Mismatch: The security key and software do not match completely.
- No security detected: No security key is being detected.

Force 2006

- **ERROR 1: INVALID KEY FOR VERSION** – This error message is directly related to the 2006 version only. Refer to the above Force & Ion heading for troubleshooting.

Force: 2002, 2003, 2004, & 2005 only

The game displays "**MAXX loading**" then "**invalid key**".

To test whether the I/O board is being detected by the motherboard, turn the game off and put DIP switch 6 (DS6) to the ON position, then turn the game back on. What are the results?

DIP Switch Response Negative:

Game boots up and displays "**Maxx loading**" followed by "**invalid key**" again.

This would indicate that the motherboard is not detecting the I/O board.

- DC power: Check for the four red LEDs on the I/O board.
- Corrupted CMOS: Try resetting the CMOS configuration on the motherboard.
- Dirty contact connections: Check and reseat the USB cable at the motherboard and I/O board.
- Defective USB cable.
- Defective I/O board.
- Defective motherboard.

DIP Switch Response Positive:

- Wrong hard drive.
- Wrong touchscreen controller.
- Memory corruption: Try DIPswitch 4 & 7 procedure.
- Corrupted CMOS: Try resetting the CMOS configuration on the motherboard.

TechTip: The Force software 2002 through 2005 requires a custom hard drive.

TechTip: The SMT2 (XL) and SMT3 (Maxx) (white box) will not function. The Force is a controller SMT4 (black box).

TechTip: If an invalid key error occurs when attempting to download newer software, chances are that the new security key was installed first and the attempted download failed. This would indicate a loading problem.

Refer to the DOWNLOADING page of this TECH 2013 document for possible solution.

HARD DRIVES

Ion \ Force

- **Disc Boot Failure:** Indicates a defective hard drive. Related to ECS motherboards.
- **Reboot and select proper boot device or insert boot media in selected boot device and press a key:** Indicates a defective hard drive. Related to ASUS motherboard. (Same as disc boot failure.)
- **A bootable device has not been detected:** Related to the Intel motherboards.
- **CRC error:** Indicates defective hard drive.
- **Operating System Not Found:** Check the IDE ribbon cable from the hard drive to the motherboard. May indicate a defective hard drive.
- **IDE ribbon cable:** Possibly damaged or defective IDE ribbon cable.
- **HDD adapter:** Laptop style hard drives use a 2.5" HDD adapter. Possible defective adapter.
- **Error 18 failed opcode:** Hard drive failure: Kernel issue.

Hard drive hardware

- **Error #97:** Defective 2.5" HDD adapter for laptop IDE hard drives.
- **Grub Loading stage 1.5 Read error:** Possible SATA data cable or SATA\IDE adapter.
- **Grub Error 15:** Problem with the master boot loader; Corrupted hard drive.

Corrupted Hard Drive

- **Bad Command or File Name:** This may indicate a corrupted hard drive or motherboard (corrupt CMOS).
Hard Drive: Reloading the CDs\DVDs may help correct the "BAD COMMAND or FILE NAME" error.
Motherboard: Performing a CMOS configuration may also help correct a "BAD COMMAND or FILE NAME" error.
- **Kernel Panic:** Possible defective motherboard, hard drive, IDE ribbon cable or SATA\IDE adapter.
- **Checking for bad blocks:** Corrupted hard drive.
- **Mounting other file system – failed:** Corrupted hard drive.
- **Rebooting to perform maintenance:** Corrupted hard drive.
- **Failed to detect motherboard device:** Corrupted hard drive.

Ion \ Force

- **LiLo-Keytable read/check sum error:** (Linux boot loader) indicates a corrupted hard drive. Try reloading software.
- **Error #97:** Defective 2.5" HDD adapter.

Force

- **Interrupt 18H Check cable...:** Indicates a defective hard drive.

Ion \ Force \ Maxx

- **Error 64, 67, 68, 94, & 97:** Indicates a defective hard drive (seen during download of new software).
- **Error 94:** May indicate that the hard drive is connected to the Secondary IDE.
 - Hard drive** must be connected to the Primary IDE connector.
 - CD\DVD-ROM drive** must be connected to the Secondary IDE port.

DOWNLOADING

Hard drive

- **Error 1:** Possible Hard drive sector problem.
- **hdc: lost interrupt:** Kernel failed. Possible DVD ROM drive, hard drive or DVD disc or interface cable.

DVD Disc

- **Error Detected #96:** Defective DVD (disc). Problem occurs during download of software.

CD \ DVD-ROM Drive

- Jumper setting: CD\DVD-ROM drive must be set to MASTER (MA).
- **Error 13.9:** Possible defective set of CD\DVDs or a defective CD\DVD-ROM drive and IDE ribbon cable.
- **Rebooting:** Game reboots after software is loaded.
The age and condition of the DVD-ROM drive are factors in downloading problems.

CMOS Configuration

- A problem with CMOS configuration can cause the motherboard to not recognize the CD\DVD-ROM drive.

Connection Problem

- Make sure that the Centronics cable is connected correctly and pushed all the way down and into place.
- IDE ribbon cable: Use the IDE ribbon cable connected between the CD\DVD-ROM drive and the motherboard.
The IDE ribbon cable going to the motherboard will go to the Secondary IDE connector on the CD\DVD-ROM drive.
- **CD-ROM error:** CD\DVD-ROM must be to Secondary IDE port.
 - ☐ Hard drive IDE ribbon cable must be connected to the Primary IDE Port (top port) on the motherboard.
 - ☐ CD\DVD-ROM drive IDE ribbon cable connects to Secondary IDE port (bottom port) on the motherboard.

Loading problem

The average down time is about 20 minutes. Should Disc 1 be ejected after a short period of time and you're instructed to install Disc 2, this would indicate that Disc 1 is faulty. Or if a second or third disc is requested, but there's only one disc in the set, then that single disc is defective.

LOCKUPS \ REBOOTS

Fans: Make sure fans are clean and clear of dirt – on the CPU chip, the power supply (if any), the hood, etc.

Screen Message: Game boot ups to the “Merit Industries, Inc” logo on the screen and does not change:

Possible problems:

- IDE ribbon cable or Centronics cable (internally)
- 2.5” HDD adapter
- Hard drive

Hardware:

- Power Supply: A weak power supply can create problems with lockups and reboots.
- Motherboard: A defective motherboard can be responsible for lockups and reboots.
- Hard drive: Problems with age and physical condition are factors in 24/7 operations.

TechTip: If the fan in the power supply has failed, it is recommended that the power supply be replaced.

Kernel Panic:

This error message represents a system crash and can be related to the motherboard, hard drive or IDE ribbon cable. Replace the hard drive first to see where problem goes. If kernel panic reappears, then the motherboard is the problem.

Verifying DMI Pool:

This error message can be related to a failed motherboard or a failed hard drive. Start with replacing the hard drive first. If the error message reappears after replacing the hard drive, then the motherboard will be at fault.

Memory: Physical Memory – Ion (DDR) \ Force (DIMMs)

- Defective DIMMs can cause games to lock up or reset and can also create graphics problems.
- Continuous repeating tone or tones may indicate a hardware memory problem with the DIMM.
Try reseating or replacing the DIMM(s).

Memory corruption: Corrupted software or missing files on the hard drive.

- Corrupted software on a hard drive can also be responsible for games rebooting and locking up.
- Clearing memory or reloading the CDs may help correct the problem. *Refer to memory clear section.*
- Some software versions had problems with lockups and reboots. *Refer to Tech 2013 for software revision.*

Voltage: Location / wall outlet / grounding.

- Heavy devices: A refrigeration unit (beer box) or compressors on the same line will cause lockups.
- Poor line voltage: The location may have a problem with poor wall voltage or grounding with their electrical system.
- Reversed polarity at the wall outlet will effect game operation.
- Improper wall voltage or low voltage can be a factor.
- Neon Lights can produce disruptive line noise.
- Proper grounding is necessary for normal game and touchscreen operation. Proper grounding is also a safety issue.

MEMORY CLEAR PROCEDURE

DIP Switches:

Linux operating system:

Maxx: Ruby, Sapphire, Jade, and Crown Edition.

Force 2003 through 2011.

Ion 2006 through 2013.

- DS 6: Hardware configuration – identifies system hardware and reconfigures the device drivers for the motherboard.
- DS 8: CMOS configuration and checksum test.
- DS 4 & 7: Complete memory clear – resets the game to the factory defaults. Clears ALL memory on hard drive. Resets CMOS on the motherboard and resets device drivers for the hardware devices.
- DS 5 & 7: Clears Tournamaxx (US\Canada) or MegaNet (international) settings.

TechTip: DS4 & 7 procedures include DS6 and DS8 functions.

DIP Switch 1

- DS1: Four selection icons (DS6, DS8, DS4 & 7, DS5 & 7) for 2007 thru 2013 only.

Reloading Software: CDs\DVDs

Reloading the discs will reformat the hard drive and restore the software to an original default level.

TechTip: If the DIP switch 4 & 7 procedure and the reloading of the software does not resolve a problem, then the actual hard drive would be the problem with a bad sector. At this point, the hard drive needs to be replaced.

TOUCHSCREENS

3M Microtouch Controllers

	<u>Controller</u>	<u>Voltage</u>	<u>Configuration</u>
Ion	USB	+5.0 VDC	Open face
Force	Serial	+12.0 VDC	Black case

TechTip: Touchscreens for Ion games no longer have or require orange and grays wires.

LED Function:

- The green LED on the controller is lit at half brightness and goes to full brightness when the screen is touched.
- Overlay functions on capacitance.

TechTip: Green LED is flashing from 1 to 5 times – possible defective touchscreen or controller.

TechTip: If the green LED is not lit, check +12 VDC. The touchscreen and/or controller may be defective. (Force controller)

Calibration:

1. Locate and press the CALIBRATE button either on the OSD board or I/O board.
2. Touch the first dot or the center of the cross that appears on the screen for 2 seconds, and then pull your finger away.
3. Touch the second dot or the center of the cross that appears on the screen for 2 seconds and then pull your finger away.
4. During the touchscreen test, the cursor should follow your finger anywhere you touch the screen.

TechTip: Depending on the platform and version of software, there may be more than one level of calibration.

Removal: Waxed dental floss // **Cleaning:** Use only a soft cloth with water or denatured alcohol.

Calibration Problems

Hardware:

- Improper calibration.
- Dirt buildup between the touchscreen and bezel.
- No grounding or floating ground.
- Defective controller.
- Defective touchscreen.

Software:

- Corrupted drivers: Run DIP switch 6
- Corrupted hard drive: Run DIP switch 4 & 7

Environment:

- Neon lights/microwave ovens will interfere with the touchscreen and should not be within 6 feet or 2 meters of the game.
- Improper grounding will affect the operation of the touchscreen.

Double-touch problem:

Taking two, three, or several cards away after only one touch. Most commonly seen in Tri-Towers, 11 Up, Solitaire, and Power Solitaire. This is a ground related problem.

Check the ground pin on the A/C plug and if wall outlets are properly grounded. (Check for faulty power strips.)

No Touch Response:

Error message: Touch Screen Controller Error: or Touch Screen Controller not Responding

This indicates that the motherboard does not detect the controller.

Possible hardware problems:

- Defective touchscreen.
- Defective USB controller (Ion) or SMT-4 controller (Force)
- Defective USB cable.
- Dirty USB cable connection at USB port on the motherboard. Try reseating or switching USB port around.
- Defective serial port. (Force platform)
- Memory corruption: Try a Dipswitch 4 & 7 memory clear.

Controller:

Is the green LED on the controller lit or active?

- **Green LED is not active:** This indicates that there is no DC voltage.
 - ▶ USB controller: Check the USB cable going to the motherboard. (+5.0 VDC)
 - ▶ SMT-4 controller: Check the +12.0 VDC power connections. (Orange +12..0 VDC)
- **Green LED active:** This indicates that there is DC voltage.

Does the green LED respond to touch?

Yes: This indicates that the touchscreen is communicating with the controller.

No: This would indicate that the touchscreen and controller are not communicating.

Possible defective touchscreen or controller.

If this is related to the Force platform, then do to the section **Serial port based controllers** for further troubleshooting.

Warning!!!

Do not install an Ion 2007 or 2007.5 hard drive into a Force game, there is a strong chance of corrupting the firmware on the SMT-4 (black) controller and leaving the controller inoperative with “**Touch controller not found**”.

Serial port based controllers:

SMT4: Force platform; SMT3: Maxx Platform; SMT2: XL Platform.

Symptom: No green LED or green LED is dim and not responding to touch.

Warning!!!

Do not install or replace the touch controller. There is a strong possibility of damaging the replacement controller.

Procedure: With game turned off, start by checking the resistance across connector points 4 & 5. If the resistance measures from 0 to 180 ohms (could possibly be higher) then the touchscreen cable is defective and the controller damaged. At this point, the touchscreen and controller will both need to be replaced. There should be about 2 to 3 MB ohms across connector points 4 & 5. Should the resistance measure good across connector points 4 & 5, then only the touchscreen controller will need to be replaced. Refer to the diagram for the connector points.

Attention: This procedure will not apply to USB controllers in Ion games.

TOUCHSCREEN OVERLAY CONNECTOR

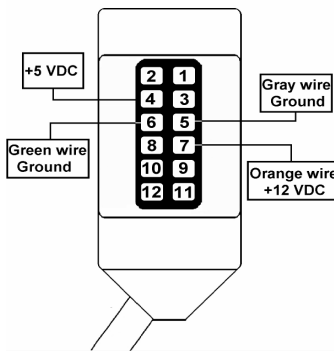

CRT Monitors: (Force Classic 13" CRT, Radion 15" CRT, and Upright 19" CRT)

- The touchscreen cable should not be positioned under or on top of the yoke of the monitor.
- The touchscreen controller cable should not be positioned near the flyback transformer.

TechTip: If the cable is not properly installed, the touchscreen response will be 180 degrees out of sync.